

## LSA 43.2/44.2 - ACT/R - 4P ALTERNATORS

Installation and maintenance

# LSA 43.2/44.2 - ACT/R - 4P ALTERNATORS

This manual concerns the alternator which you have just purchased.

The latest addition to a whole new generation of alternators, this range benefits from the experience of the leading manufacturer worldwide, using advanced technology and incorporating strict quality control.

## SAFETY MEASURES

Before using your machine for the first time, it is important to read the whole of this installation and maintenance manual.

All necessary operations and interventions on this machine must be performed by a qualified technician.

Our technical support service will be pleased to provide any additional information you may require.

The various operations described in this manual are accompanied by recommendations or symbols to alert the user to the potential risk of accidents. It is vital that you understand and take notice of the different warning symbols used.

**CAUTION**

Warning symbol for an operation capable of damaging or destroying the machine or surrounding equipment.



Warning symbol for general danger to personnel.



Warning symbol for electrical danger to personnel.

Note: LEROY-SOMER reserves the right to modify the characteristics of its products at any time in order to incorporate the latest technological developments. The information contained in this document may therefore be changed without notice.

We wish to draw your attention to the contents of this maintenance manual. By following certain important points during installation, use and servicing of your alternator, you can look forward to many years of trouble-free operation.

## WARNING SYMBOLS

A set of self-adhesive stickers depicting the various warning symbols is included with this maintenance manual. They should be positioned as shown in the drawing below once the machine has been fully installed.

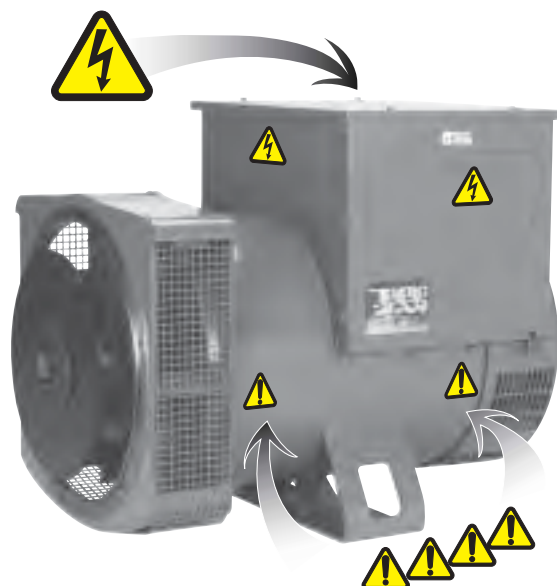

Copyright 2001: MOTEURS LEROY-SOMER

This document is the property of:  
MOTEURS LEROY-SOMER

It may not be reproduced in any form without prior authorization.

All brands and models have been registered and patents applied for.

# LSA 43.2/44.2 - ACT/R - 4P ALTERNATORS

## CONTENTS

### 1 - RECEIPT

1.1 - Standards and safety measures .....	4
1.2 - Inspection .....	4
1.3 - Identification.....	4
1.4 - Storage .....	4

### 2 - TECHNICAL CHARACTERISTICS

2.1 - Electrical characteristics .....	5
2.2 - Mechanical characteristics.....	5
2.3 - COMPOUND excitation system.....	6

### 3 - INSTALLATION - COMMISSIONING

3.1 - Assembly .....	7
3.2 - Inspection prior to first use.....	7
3.3 - Terminal connection diagrams.....	8
3.4 - Commissioning .....	9
3.5 - Settings.....	9
3.6 - Adjustment procedures .....	10
3.7 - Compounding transformer .....	11
3.8 - Parallel operation.....	13
3.9 - Adjusting the excitation system .....	13
3.10 - Phase identification .....	15

### 4 - SERVICING - MAINTENANCE

4.1 - Safety measures .....	16
4.2 - Routine maintenance .....	16
4.3 - Fault detection .....	16
4.4 - Mechanical defects .....	17
4.5 - Electrical faults.....	17
4.6 - Dismantling, reassembly.....	19
4.7 - Table of characteristics .....	21

### 5 - SPARE PARTS

5.1 - First maintenance parts .....	22
5.2 - Bearing designations .....	22
5.3 - Technical support service .....	22
5.4 - Exploded view, parts list .....	23

# LSA 43.2/44.2 - ACT/R - 4P

## ALTERNATORS

### RECEIPT

## 1 - RECEIPT

### 1.1 - Standards and safety measures

Our alternators comply with most international standards and are compatible with:

- The recommendations of the

**International Electrotechnical Commission**

IEC 34-1, (EN 60034)

- The recommendations of the

**International Standards Organisation ISO 8528**

- the European Community directive 89/336/EEC on Electromagnetic Compatibility (EMC)

- **The European Community directives**

**73/23/EEC and 93/68/EEC (Low Voltage Directive)**

They are CE marked with regard to the LVD (Low Voltage Directive) in their role as a machine component. A declaration of incorporation can be supplied on request.

Before using your generator for the first time, read carefully the contents of this installation and maintenance manual, supplied with the machine. All operations performed on the generator should be undertaken by qualified personnel trained in the commissioning, servicing and maintenance of electrical and mechanical components. This maintenance manual should be retained for the whole of the machine's life and be handed over with the contractual file.

The various operations described in this manual are accompanied by recommendations or symbols to alert the user to the potential risk of accidents. It is vital that you understand and take notice of the different warning symbols used.

### 1.2 - Inspection

On receipt of your alternator, check that it has not suffered any damage in transit. If there are obvious signs of knocks, contact the transporter (you may be able to claim on their insurance) and after a visual check, turn the machine by hand to detect any malfunction.

### 1.3 - Identification

The alternator is identified by means of a nameplate glued to the frame.

Make sure that the nameplate on the machine conforms to your order.

The machine name is defined according to various criteria (see below).

Example of description: **LSA 43.2 M4 E 51/4 -**

- LSA: name used in the PARTNER range
  - M: Marine/C: Cogeneration/T: Telecommunications
- 43.2: Machine type
- M4: Model
- E: Excitation system  
(C:AREP/J:SHUNT/E:COMPOUND)
- 51/4: Winding number/number of poles

#### 1.3.1 - Nameplate

So that you can identify your machine quickly and accurately, we suggest you write its specifications on the nameplate below.

### 1.4 - Storage

Prior to commissioning, machines should not be stored in humid conditions: In conditions of relative humidity of more than 90%, the machine insulation can drop very rapidly, to just above zero at around 100%; monitor the state of the anti-rust protection on unpainted parts.

For storage over an extended period, the machine can be placed in a sealed enclosure (heatshrunk plastic for example) with dehydrating sachets inside, away from significant and frequent variations in temperature to avoid the risk of condensation during storage.

If the area is affected by vibration, try to reduce the effect of these vibrations by placing the generator on a damper support (rubber disc or similar) and turn the rotor a fraction of a turn once a fortnight to avoid marking the bearing rings.

<b>ALTERNATEURS PARTNER ALTERNATORS</b>																																														
<p>LSA <input type="text"/> Date <input type="text"/></p> <p>N° <input type="text"/> Hz <input type="text"/></p> <p>Min<sup>-1</sup>/R.P.M. <input type="text"/> Protection <input type="text"/></p> <p>Cos Ø /P.F. <input type="text"/> Cl. ther. / Th. class <input type="text"/></p> <p>Régulateur/A.V.R. <input type="text"/></p> <p>Altit. <input type="text"/> m Masse / Weight <input type="text"/></p> <p>Rlt AV/D.E bearing <input type="text"/></p> <p>Rlt AR/N.D.E bearing <input type="text"/></p> <p>Graisse / Grease <input type="text"/></p> <p>Valeurs excit / Excit. values <input type="text"/></p> <p>en charge / full load <input type="text"/></p> <p>à vide / at no load <input type="text"/></p>	<p style="text-align: center;"><b>PUISSANCE / RATING</b></p> <table border="1" style="width: 100%; border-collapse: collapse;"> <tr> <td>Tension Voltage</td> <td><input type="text"/></td> <td><input type="text"/></td> <td><input type="text"/></td> <td>V</td> </tr> <tr> <td></td> <td><input type="text"/></td> <td><input type="text"/></td> <td><input type="text"/></td> <td>Ph.</td> </tr> <tr> <td>Connex.</td> <td><input type="text"/></td> <td><input type="text"/></td> <td><input type="text"/></td> <td></td> </tr> <tr> <td>Continue</td> <td><input type="text"/></td> <td><input type="text"/></td> <td><input type="text"/></td> <td>kVA</td> </tr> <tr> <td>Continuous</td> <td><input type="text"/></td> <td><input type="text"/></td> <td><input type="text"/></td> <td>kW</td> </tr> <tr> <td>40°C</td> <td><input type="text"/></td> <td><input type="text"/></td> <td><input type="text"/></td> <td>A</td> </tr> <tr> <td>Secours</td> <td><input type="text"/></td> <td><input type="text"/></td> <td><input type="text"/></td> <td>kVA</td> </tr> <tr> <td>Std by</td> <td><input type="text"/></td> <td><input type="text"/></td> <td><input type="text"/></td> <td>kW</td> </tr> <tr> <td>27°C</td> <td><input type="text"/></td> <td><input type="text"/></td> <td><input type="text"/></td> <td>A</td> </tr> </table>	Tension Voltage	<input type="text"/>	<input type="text"/>	<input type="text"/>	V		<input type="text"/>	<input type="text"/>	<input type="text"/>	Ph.	Connex.	<input type="text"/>	<input type="text"/>	<input type="text"/>		Continue	<input type="text"/>	<input type="text"/>	<input type="text"/>	kVA	Continuous	<input type="text"/>	<input type="text"/>	<input type="text"/>	kW	40°C	<input type="text"/>	<input type="text"/>	<input type="text"/>	A	Secours	<input type="text"/>	<input type="text"/>	<input type="text"/>	kVA	Std by	<input type="text"/>	<input type="text"/>	<input type="text"/>	kW	27°C	<input type="text"/>	<input type="text"/>	<input type="text"/>	A
Tension Voltage	<input type="text"/>	<input type="text"/>	<input type="text"/>	V																																										
	<input type="text"/>	<input type="text"/>	<input type="text"/>	Ph.																																										
Connex.	<input type="text"/>	<input type="text"/>	<input type="text"/>																																											
Continue	<input type="text"/>	<input type="text"/>	<input type="text"/>	kVA																																										
Continuous	<input type="text"/>	<input type="text"/>	<input type="text"/>	kW																																										
40°C	<input type="text"/>	<input type="text"/>	<input type="text"/>	A																																										
Secours	<input type="text"/>	<input type="text"/>	<input type="text"/>	kVA																																										
Std by	<input type="text"/>	<input type="text"/>	<input type="text"/>	kW																																										
27°C	<input type="text"/>	<input type="text"/>	<input type="text"/>	A																																										
<b>LR 0021</b> <b>Conforme à C.E.I 34-1(1994). According to I.E.C 34-1(1994).</b>																																														

Made by Leroy Somer - 1 024 930/b

# LSA 43.2/44.2 - ACT/R - 4P

## ALTERNATORS

### TECHNICAL CHARACTERISTICS

## 2 - TECHNICAL CHARACTERISTICS

### 2.1 - Electrical characteristics

These are alternators without slip-rings or brushes, with A.C. exciter rectified by rotating diodes. Excitation occurs by combining the voltage supplied by an auxiliary winding with that produced by the current drawn by the alternator in the secondary of a current transformer connected in series with the main winding. This combination ensures accurate voltage regulation whatever the current and power factor: voltage regulation can be improved by using a shunt type voltage regulator.

The entire magnetic circuit of the exciter is made of laminated steel sheets to obtain the fastest response while continuing to provide sufficient remanent voltage for automatic build-up in all conditions.

The compound system can be adjusted by:

- adjusting the air gap on the transformer, which adjusts the no-load excitation voltage,
- adjusting the tapping points on the transformer secondary for the on-load voltage.

Both these adjustments are made in such a way that the excitation supplied by the compound system is greater than that required to obtain the rated voltage. Excess excitation current is shunted by a voltage regulator (AVR), which measures the voltage at the alternator terminals.

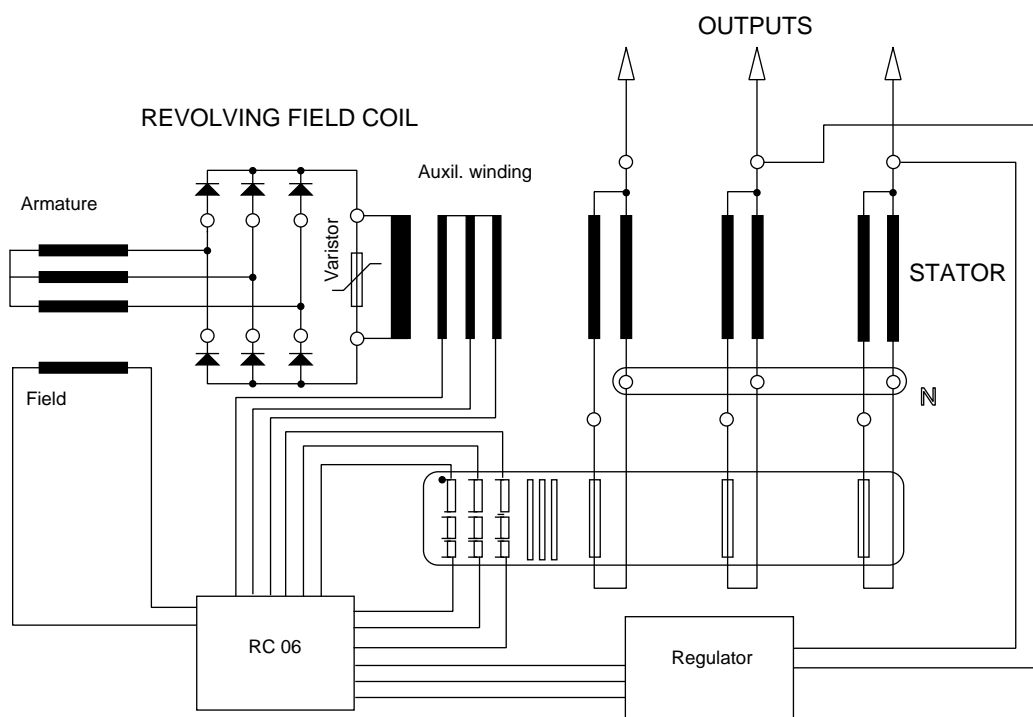

#### 2.1.1 - Options

- Stator temperature detection sensors
- Space heaters

### 2.2 - Mechanical characteristics

- Steel frame
  - Cast iron end shields
  - Greasable ball bearings
  - Mounting arrangements:
- IM 1201 (MD 35) single-bearing with feet and SAE flanges/  
coupling discs

#### IM 1001 (B 34 )

Two-bearing with SAE flange and standard cylindrical shaft extension.

- Drip-proof machine, self-cooled
- Degree of protection: IP 23

#### 2.2.1 - Options

- Protection against harsh environments
  - Air inlet filter, air outlet labyrinth seals
- Alternators fitted with air inlet filters should be derated by 5% (power).  
To prevent excessive temperature rise caused by clogged filters, it is advisable to fit the stator winding with thermal sensors (PTC or PT100).

# LSA 43.2/44.2 - ACT/R - 4P

## ALTERNATORS

### TECHNICAL CHARACTERISTICS

### 2.3 - COMPOUND excitation system

The Compound excitation system is controlled by the R 129 electronic AVR.



### 2.3.2 - R129 power supply connection

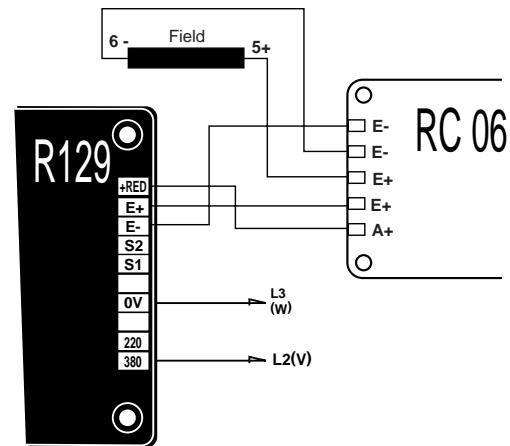

### 2.3.1 - AVR characteristics

#### 2.3.1.1 - Basic operation

Note: \* : ACW : Anticlockwise

\* : CW : Clockwise

- Negative regulator (current shunt)
- Voltage regulation  $\pm 1\%$  between on-load and full-load operation (non-distorting) at steady state speed and temperature conditions
- Voltage adjustment range for the internal potentiometer (P2) 50 and 60 Hz
- 220 V measurement input: 170 to 250 V
- 380 V measurement input: 340 to 500 V
- External potentiometer: 470  $\Omega$  - 1 W ( $\pm 10\%$  adjustment)
- Single-phase detection 2 VA isolated via transformer
- Rated controlled power (D.C.): 90V.7A - Peak (10 seconds): 100V.10 A
- Rated shunt current: 4 A; peak: 10 A

#### 2.3.1.2 - External potentiometer: 470 $\Omega$ - 1W

Connected in place of jumper J2.

These 2 terminals can be used to connect an external module in parallel on the mains.

### 2.3.3 - RC 06 rectifier bridge connection

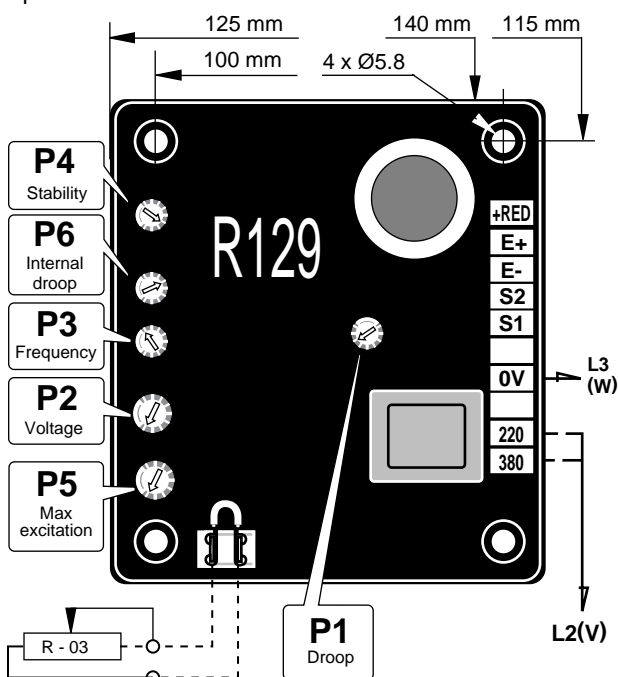
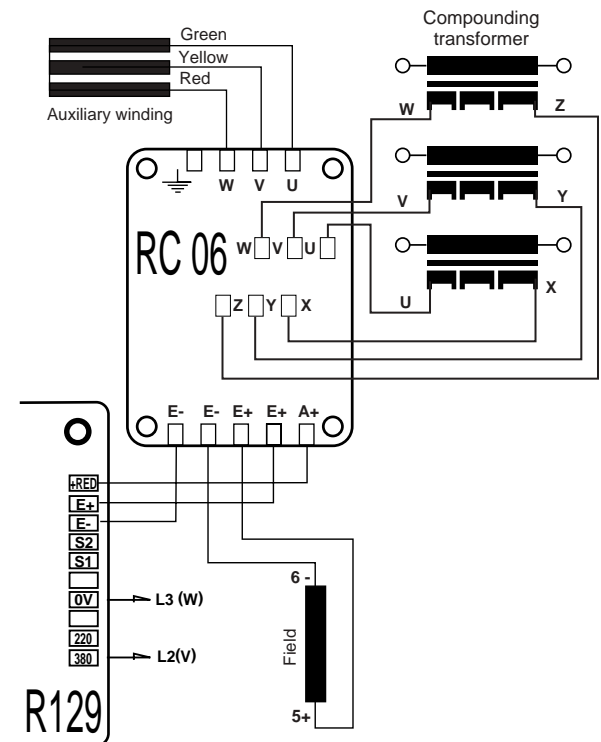

# LSA 43.2/44.2 - ACT/R - 4P ALTERNATORS INSTALLATION

## 3 - INSTALLATION

### 3.1 - Assembly



All mechanical handling operations must be undertaken using approved equipment. Whilst being handled, the machine should remain horizontal.

#### 3.1.1 - Handling

The generously-sized lifting rings are for handling the alternator alone. They must not be used to lift the genset. Choose a lifting system which respects the positioning of the rings.

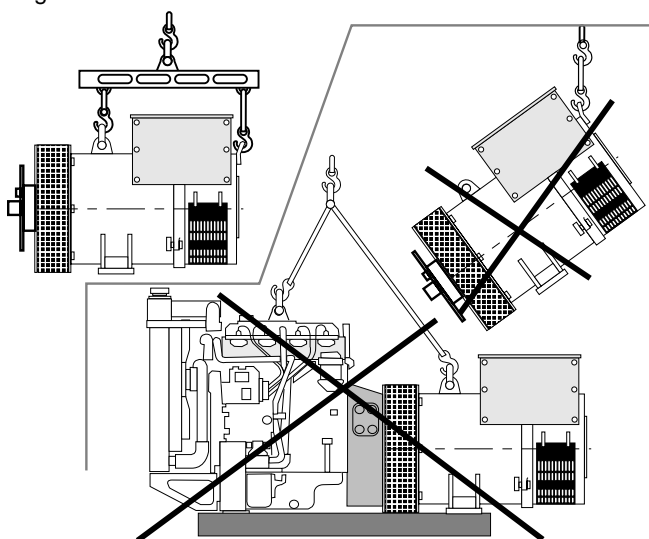

#### 3.1.2 - Coupling

##### 3.1.2.1 - Single-bearing alternator

Before coupling the machines, check that they are compatible by:

- Undertaking a torsional analysis of the transmission on the genset
- Checking the dimensions of the flywheel and its housing, the flange, coupling discs and offset

**CAUTION**

When coupling the alternator to the prime mover, the holes of the coupling discs should be aligned with the flywheel holes by cranking the engine. Do not use the alternator fan to turn the rotor.

Tighten the coupling disc screws to the recommended torque (see section 4.6.2) and check that there is lateral play on the crankshaft.

##### 3.1.2.2 - Double-bearing alternator

- Semi-flexible coupling

Careful alignment of the machines is recommended, checking that the concentricity and parallelism of both parts of the coupling does not exceed 0.1 mm.

**CAUTION**

This alternator has been balanced with a 1/2 key.

#### 3.1.3 - Location

Ensure that the ambient temperature in the room where the alternator is placed cannot exceed 40°C for standard power ratings (for temperatures > 40°C, apply a derating coefficient). Fresh air, free from damp and dust, must be able to circulate freely around the air intake grilles on the opposite side from the coupling. It is essential to prevent not only the recycling of hot air from the machine or engine, but also exhaust fumes.

### 3.2 - Inspection prior to first use

#### 3.2.1 - Electrical checks



Under no circumstances should an alternator, new or otherwise, be operated if the insulation is less than 1 megohm for the stator and 100,000 ohms for the other windings.

There are two possible methods for restoring these minimum values.

- a) Dry out the machine for 24 hours in a drying oven at a temperature of 110°C (without the AVR).
- b) Blow hot air into the air inlet, having made sure that the machine is rotating with the exciter field disconnected.
- c) Run in short-circuit mode (disconnect the AVR):
  - Short-circuit the three output terminals (power) using connections capable of supporting the rated current (try not to exceed 6 A/mm<sup>2</sup>).
  - Insert a clamp ammeter to monitor the current passing through the short-circuit connections.
  - Connect a 48 Volt battery in series with a rheostat of approximately 10 ohms (50 W) to the exciter field terminals, respecting the polarity.
  - Open fully all the alternator openings.
  - Run the alternator at its rated speed, and adjust the exciter field current using the rheostat to obtain the rated output current in the short-circuit connections.

Note: After an extended downtime, in order to avoid these problems, we recommend the use of space heaters, as well as turning over the machine from time to time. Space heaters are only really effective if they are working continuously while the machine is stopped.

#### 3.2.2 - Mechanical checks

Before starting the machine for the first time, check that:

- the fixing bolts on the feet are tight,
- the cooling air is drawn in freely,
- the protective grilles and housing are correctly in place,
- the standard direction of rotation is clockwise as seen from the shaft end (phase rotation in order 1-2-3) For anticlockwise rotation, swap 2 and 3,
- The winding connection corresponds to the site operating voltage (see section 3.3).

# LSA 43.2/44.2 - ACT/R - 4P

## ALTERNATORS

### INSTALLATION

### 3.3 - Terminal connection diagrams

To modify the connection, change the position of the terminal cables. The winding code is specified on the nameplate.



**Any intervention on the alternator terminals during reconnection or checks should be performed with the machine stopped.**

Connection code	Voltage L.L	Factory connection				
<p><b>(D)</b> 3 phases</p>	<table border="1" style="width: 100%; border-collapse: collapse;"> <tr> <td style="width: 50%;">50 Hz</td> <td style="width: 50%;">380 - 415</td> </tr> <tr> <td>60 Hz</td> <td>380 - 480</td> </tr> </table> <p>R 129 voltage sensing: 0 =&gt; (T3) / 380 V =&gt; (T2)</p>	50 Hz	380 - 415	60 Hz	380 - 480	
50 Hz	380 - 415					
60 Hz	380 - 480					
<p><b>(F)</b> 1 phase or 3 phases</p>	<table border="1" style="width: 100%; border-collapse: collapse;"> <tr> <td style="width: 50%;">50 Hz</td> <td style="width: 50%;">220 - 240</td> </tr> <tr> <td>60 Hz</td> <td>220 - 240</td> </tr> </table> <p>R 129 voltage sensing: 0 =&gt; (T3) / 380 V =&gt; (T2)</p>	50 Hz	220 - 240	60 Hz	220 - 240	
50 Hz	220 - 240					
60 Hz	220 - 240					

#### 3.3.1 - Option connection diagram

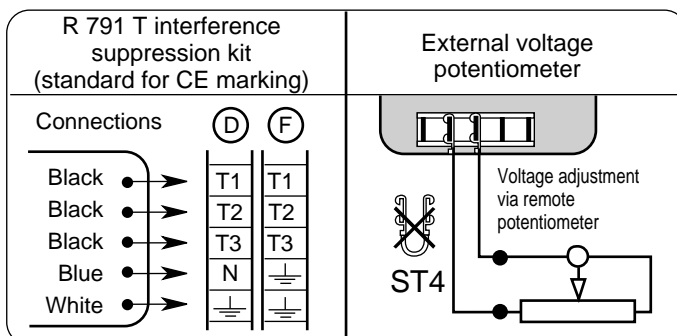



# LSA 43.2/44.2 - ACT/R - 4P

## ALTERNATORS

### INSTALLATION

### 3.3.2 - Connection checks



Electrical installations must comply with the current legislation in force in the country of use.

Check that:

- The residual circuit-breaker complies with legislation on protection of personnel in force in the country of use, and has been correctly installed on the alternator power output as close as possible to the alternator. (In this case, disconnect the blue wire of the R 791 interference suppression module linking the neutral).
- Any protection devices in place have not been tripped.
- If there is an external AVR, the connections between the alternator and the cabinet are made in accordance with the connection diagram.
- There is no short-circuit between phase or phase-neutral between the alternator output terminals and the genset control cabinet (part of the circuit not protected by circuit-breakers or cubicle relays).
- The machine has been connected with the busbar separating the terminals as shown in the terminal connection diagram.

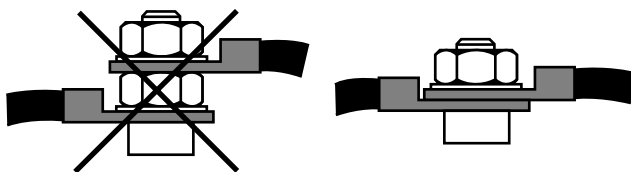

### 3.3.3 - Electrical checks on the AVR

- Check that all connections have been made properly as shown in the attached wiring diagram.

### 3.4 - Commissioning



**The machine can only be started up and used if the installation is in accordance with the regulations and instructions defined in this manual.**

The machine is tested and set up at the factory. When first used with no load, make sure that the drive speed is correct and stable (see the nameplate). On application of the load, the machine should achieve its rated speed and voltage; however, in the event of abnormal operation, the machine setting can be altered (follow the adjustment procedure in section 3.5). If the machine still operates incorrectly, the cause of the malfunction must be located (see section 4.4).

### 3.5 - Setting up



The various adjustments during tests must be made by a qualified engineer. Take care that the drive speed specified on the nameplate is reached before commencing adjustment. After operational testing, replace all access panels or covers.

The AVR or the compound system are used to make any adjustments to the machine.

#### 3.5.1 - Settings for the R 129 (factory-mounted)

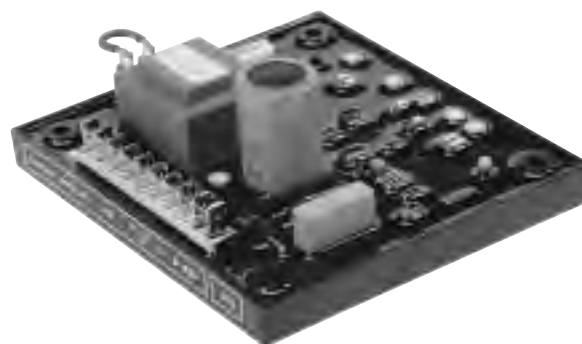

- P1 is set to minimum, i.e. fully ACW\*
- P2 is set according to the required voltage  
Possible voltage ranges  
220 V connection: 170 V to 250 V  
380 V connection: 340 V to 525 V
- P3 setting for the frequency knee point below which the U/F and LAM functions are activated (See figure 1).
- P4 optimum test setting to obtain the best response time in transient operation on load impact/shedding
- P5 set according to the short-circuit current of the field excitation power rating. Minimum voltage setting: 80 V
- P6 is used to adjust the quadrature droop for a parallel connection when there is no CT. It is set to minimum i.e. fully ACW.\*

#### 3.5.1.1 - R 129 adjustments (spare parts)

When the AVR leaves the factory, potentiometers P1, P5 and P6 are normally set to minimum (fully ACW\*).

- P2 is set for the rated voltage (220 V or 380 V depending on the connection).
  - P3 is set for the frequency knee point (either 48 Hz or 58 Hz).
- To avoid incorrect operation, proceed as follows:
- 1 - Turn P2 fully ACW\* and check that P1, P5 and P6 are the same.
  - 2 - Turn P3 fully CW.
  - 3 - Set the prime mover to its rated speed.
  - 4 - Set P4 to its mid-point setting.
  - 5 - Set P2 to obtain the required voltage.
  - 6 - Set the driving speed to 48 Hz or 58 Hz or other frequency.

# LSA 43.2/44.2 - ACT/R - 4P ALTERNATORS INSTALLATION

7 - Turn P3 ACW\* until the alternator voltage starts to drop. Then turn P3 gently CW. This adjustment determines the frequency knee point below which the U/F function comes into operation.

8 - To determine the P4 stability setting, load the alternator. Perform some loading/load shedding operations. In the event of oscillations, adjust P4 accordingly to achieve stability (repeat this operation several times).

9 - The short-circuit current is set by P5.

10 - The quadrature droop for parallel operation is set by P1 or P6.

## 3.6 - Adjustment procedure using R 129

### 3.6.1 - Measuring instruments required

On the AVR:

- Analogue D.C. ammeter to measure I R (E-,E-) 1 Amp rating
- Analogue D.C. voltmeter to measure U exc, rating: 30 V
- A.C. voltmeter to measure U d (terminals 0, 220 V or 0, 380 V)

At the output:

- Wattmeter: KW ~ on-load

On the control cabinet:

- Frequency meter: f or tachometer
- A.C. voltmeter: U alt (alternator voltage)
- Ammeter: I ~ on-load
- Cable grip (I R , U exc measurements)

### 3.6.2 - Initial connections

Check the connections against the machine's internal connection diagram. The compounding transformer must be connected according to the "100%" connections (see section 4 - 2 - 2). The air gap should be small (0.5 mm) and uniform.

### 3.6.3 - No-load adjustment

Run the alternator at its no-load speed (see decision table).

- List the operations and faults.
- Record the IRØ value of the current that is shunted by the AVR and the U ExcØ value of the no-load excitation voltage.

### 3.6.4 - On-load adjustment

(Assuming the alternator has been set to UN at no load)

- Run the alternator at its no-load rated speed.
- Record the IRØ values.
- If the rated load is not available, apply a sufficiently high ( $\geq 30\%$  Sn) and inductive (power factor  $\leq 0.9$  AR) load.
- Record the values of the voltage at the alternator terminals (U alt C), the shunt current (IRC) and the excitation voltage (U excC).

### 3.6.5 - Operation

The AVR is capable of shunting 4 A continuously and 10 A in peak operation: the shunt current is chopped and the dissipated power is less than 50 W.

The way to check AVR operation is to measure the current (IR) shunted by the AVR and the excitation voltage (U exc) (terminals E+,E- on the AVR). Use galvanometer D.C measuring instruments (rating = 1-3 A and 30 V) to measure the voltages and chopped currents.

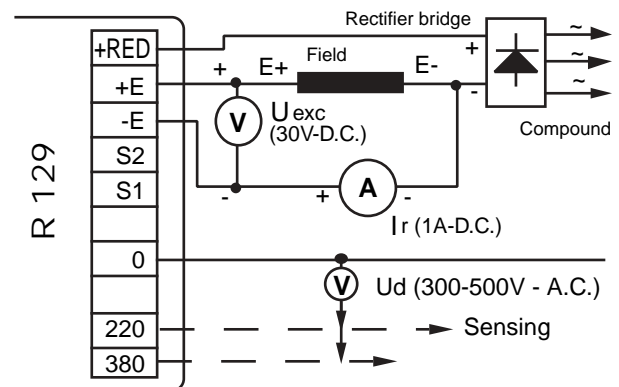

For correct adjustment of the compound system and in normal operating conditions, the Uexc/Ir ratio at no load and on load should be between 20 and 30 (25 = factory setting); for example:

	At no load	On load
<b>IR (A)</b>	0.22 - 0.33	0.73 - 1.1
<b>U exc (V)</b>	6.5	22
<b>U exc/Ir</b>	20 ... 30	20 ... 30
<b>U alt (V)</b>	400	400
<b>Frequency</b>	51.5	50

#### a) Adjustment of the voltage U R at no load by adjusting the air gap

I R = 0 means that the AVR does not shunt any current:

- a) - Compound excitation too low
- b) - Voltage setting too high (AVR)

Uexc/Ir < 5 means that the AVR cannot shunt any more current:

- a) - Compound excitation too high
- b) - Voltage setting too low (AVR)

# LSA 43.2/44.2 - ACT/R - 4P ALTERNATORS INSTALLATION

## 3.7 - Compounding transformer

### 3.7.1 - Outline and diagram

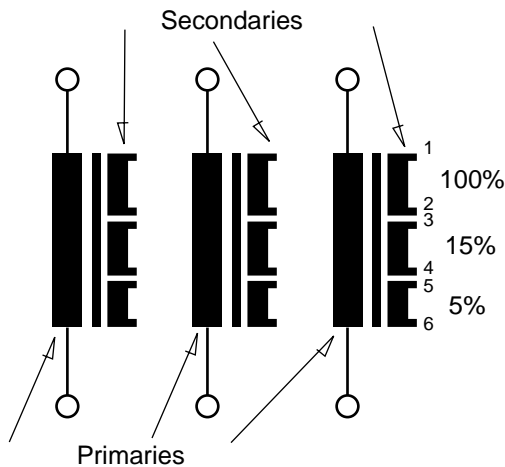

### 3.7.2 - How to adjust the compounding transformer (no AVR)

There are two ways to adjust the compounding transformer:

- The air gap "E" on the transformer
- The number of turns on the secondary windings "n"

#### 3.7.2.1 - Adjustment of the voltage U R at no load by adjusting the air gap

- Set the speed to a value 3 or 4% above the rated speed of the alternator U R.
- If the no-load voltage is too low, increase the air gap "E". To do this, loosen the nut (1) and the locknut (2) and turn the screw (3) to the right (clockwise).
- If the no-load voltage is too high, decrease the air gap "E". To do this, loosen the nut (1) and the locknut (2) and turn the screw (3) to the left (anticlockwise), then tap the adjustable yoke (4).
- Adjust the air gap until the voltage value equals the rated voltage, then tighten the nut (1) and locknut (2).
- Perform these operations on both stirrup clamps to obtain the same air gap ( $\pm 10\%$ ) along the entire length of the transformer.

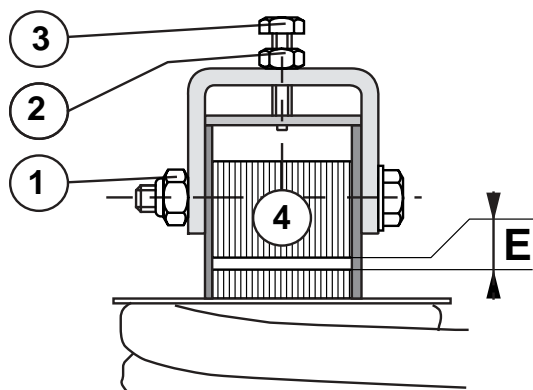

#### 3.7.2.2 - Adjustment of the voltage U R on load by selecting the number of secondary turns

The turns ratio is adjusted by changing the input and output connections on the transformer secondaries. Each secondary coil has 3 separate windings made up of "n" turns, 15% "n" turns, and 5% "n" turns.

The number of turns on the secondary can therefore be adjusted in steps of 5% between "n" - 20% and "n" + 20%.

The diagrams below show the 9 possible connection types and the corresponding number of turns "n".

Connect all 3 coils the same way.

**CAUTION:**

After each modification to the number of turns, the air gap must be reset at no load.

**Distribution of turns in the secondary coils of the compounding transformer.**

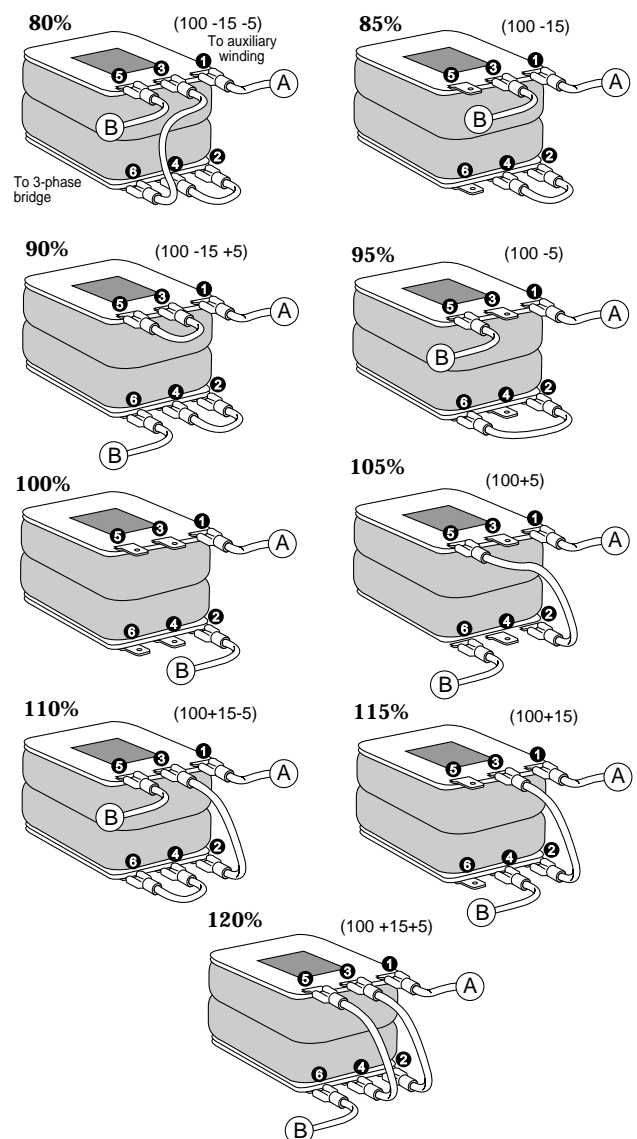

If the primary or secondary coils are reverse-wound, or if the auxiliary stator winding is reverse-connected, invert the inputs and outputs on the secondary windings.

# LSA 43.2/44.2 - ACT/R - 4P

## ALTERNATORS

### INSTALLATION

#### DECISION TABLE

No-load adjustment				
Case	U alt	I R Ø - DC AMP		
		< 0.10 A	0.2 – 0.4 A	> 0.5 A
1	~ 0	A1	Not possible	Not possible
2	5 - 15% UN (UN = alternator rated voltage)	F1	F2	Not possible
3	40 - 60% UN	F3 or F7	D4	F4 or F7
4	70 -90% UN	A2 or F7	A3	A3
5	95 -100% UN	A2	A3	A3 and A4
6	UN ( $\pm 1\%$ )	A2	A5	A4
7	100 -105% UN	A3 and A2	A3	A3 and A4
8	110 -115% UN	F5	A3 and A4	A4 and A3
9	120 -135% UN	F5	F6	F6
10	Oscillations	A6	A6 or F12	A6 or F12

On-load adjustment								
Case	U alt	U excC $\leq$ U exc Ø	U excC $\gg$ U exc Ø					
			I RC $\leq$ I R Ø		I RC $\gg$ I R Ø			
		I RC - DC AMP		r = U excC / I R Ø				
		< 0.1 A	> 0.2 A	r > 30	20 $\leq$ r $\leq$ 30	r < 20		
1	0 -94% UN	F3	A7 and F11	F2	A7 and F11	F2	F2	
2	94 -98% UN	Not possible	A7 and F11	A7+F9+F10	A7+F10+F11	F9 and F10	A8+F9+F10	
3	98 -102% UN	Not possible	A7	A7	A7	OK	A8	
4	102 -106% UN	Not possible	F2+A7+F9	A7+F9+F10	A7 and F9	F9 and F10	A8+F10+F11	
5	> 106% UN	Not possible	F5	F2	F2	F2	A8 and F11	
6	Oscillations	-	A7	A7	A6 or F12	A6 or F12	A6 or F12	
			F8 and F3					

#### Operations:

- A1** : Flash the field with a battery (see section 7.6)
- A2** : Increase the air gap on the compounding transformer (see section 4.2)
- A3** : Adjust the voltage
- On the AVR: via potentiometer (P2)
  - Or via the external potentiometer
- A4** : Decrease the air gap on the compounding transformer (see section 4.2)
- A5** : Final no-load adjustment. I R should be between 0.2 and 0.4 A and the Uexc/IR ratio should be between 20 and 30.
- If Uexc/IR > 30 = A2
  - If Uexc/IR < 20 = A4
- A6** : Adjust the stability using potentiometer (P4)
- Note: Hunting may be caused by speed variations (defective injectors or speed regulator).
- A7** : Disconnect the load and stop the genset
- Decrease the number of secondary turns on the compounding transformer (see section 4.2)
  - Restart and re-adjust at no load
- A8** : Disconnect the load and stop the genset
- Increase the number of secondary turns on the compounding transformer (see section 4.2)
  - Restart and re-adjust at no load

**OK** : Correct setting

#### Faults:

- F1** : Excitation circuit open
- F2** : AVR fault
- F3** : Fault on rotating diodes, rectifier bridge or exciter armature
- F4** : Voltage sensor incorrectly connected
- F5** : AVR not connected, incorrectly connected or faulty
- F6** : Compounding transformer incorrectly connected (100% coil not connected), short-circuited or not suitable (replace)
- F7** : Incorrect connection of the main winding
- F8** : Compounding transformer incorrectly connected, short-circuited or not suitable (replace)
- F9** : Internal quadrature droop or quadrature droop via CT in operation. Turn potentiometers P1 and P6 fully anticlockwise
- F10** : The load is distorting (e.g. rectifiers, inverters)
- F11** : Compounding transformer incorrectly connected (not in phase). Check the auxiliary winding phases in relation to the compounding transformer.
- F12** Unintentional LAM operation
- Check the frequency - Adjust the V/Hz setting P3

# LSA 43.2/44.2 - ACT/R - 4P

## ALTERNATORS

### INSTALLATION

### 3.8 - Parallel operation

For parallel operation with the R 129 AVR, please contact Leroy Somer.

For continuous operation in parallel with the mains with additional power factor regulator R 726, please refer to the relevant manual.

### 3.9 - Adjusting the excitation system

Manual operation, , no AVR, with rheostat

The basic settings for the compound system are made for the rated voltage  $U_N$  corresponding to the winding type: for example, for winding 1 with connection D, the rated voltage is 400 V at 50 Hz and 480 V at 60 Hz.

Note: Without an AVR, the alternator voltage varies with the speed.

#### 3.9.1 - Description of rheostat operation

The rheostat is connected in parallel with the exciter field. It is in series with a 20 Ohm limiting resistor.

It comprises 3 sections of different cross-section.

Position 0 corresponds to "fully ACW" and position 4/4 to "fully CW" as seen from the drive shaft.

The equivalent of this rheostat is an adjustable resistor or a constant cross-section rheostat of 180 Ohms - 180 Watt (1A).

#### Operation

The rheostat shunts part of the excitation current produced by the compound system.

- The alternator voltage increases as the rheostat is rotated clockwise.

- For the same variation of resistance, the rheostat has a far greater effect on the voltage on load than at not load:

the no-load voltage should not be adjusted using the rheostat; adjustment is via the air gap on the compounding transformer.

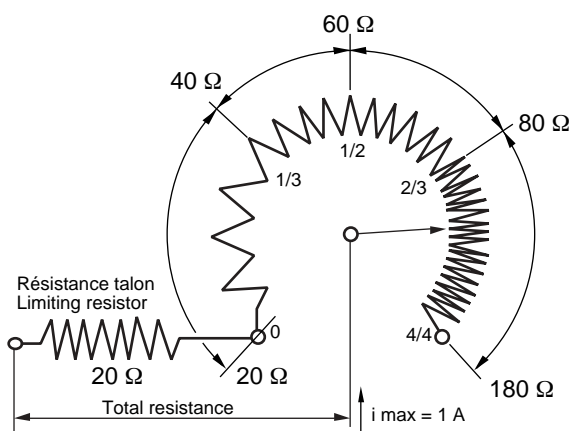

# LSA 43.2/44.2 - ACT/R - 4P ALTERNATORS INSTALLATION

### 3.9.2 - Flow chart showing how to adjust the compound excitation system (no AVR) with a rheostat

**U T** : Voltage at the alternator terminals indicated in the table

**U A** : Alternator voltage

At standstill

1) Connect the power cables as shown in the connection diagram.

2) Set the rheostat to 40 or 60 Ω depending on the load conditions (see table on page ).

3) Loosen the yoke on the compounding transformer (page 19) to be able to adjust the air gap during operation.

4) Connect the secondaries on the compounding transformer according to the 100% connection (page 12).

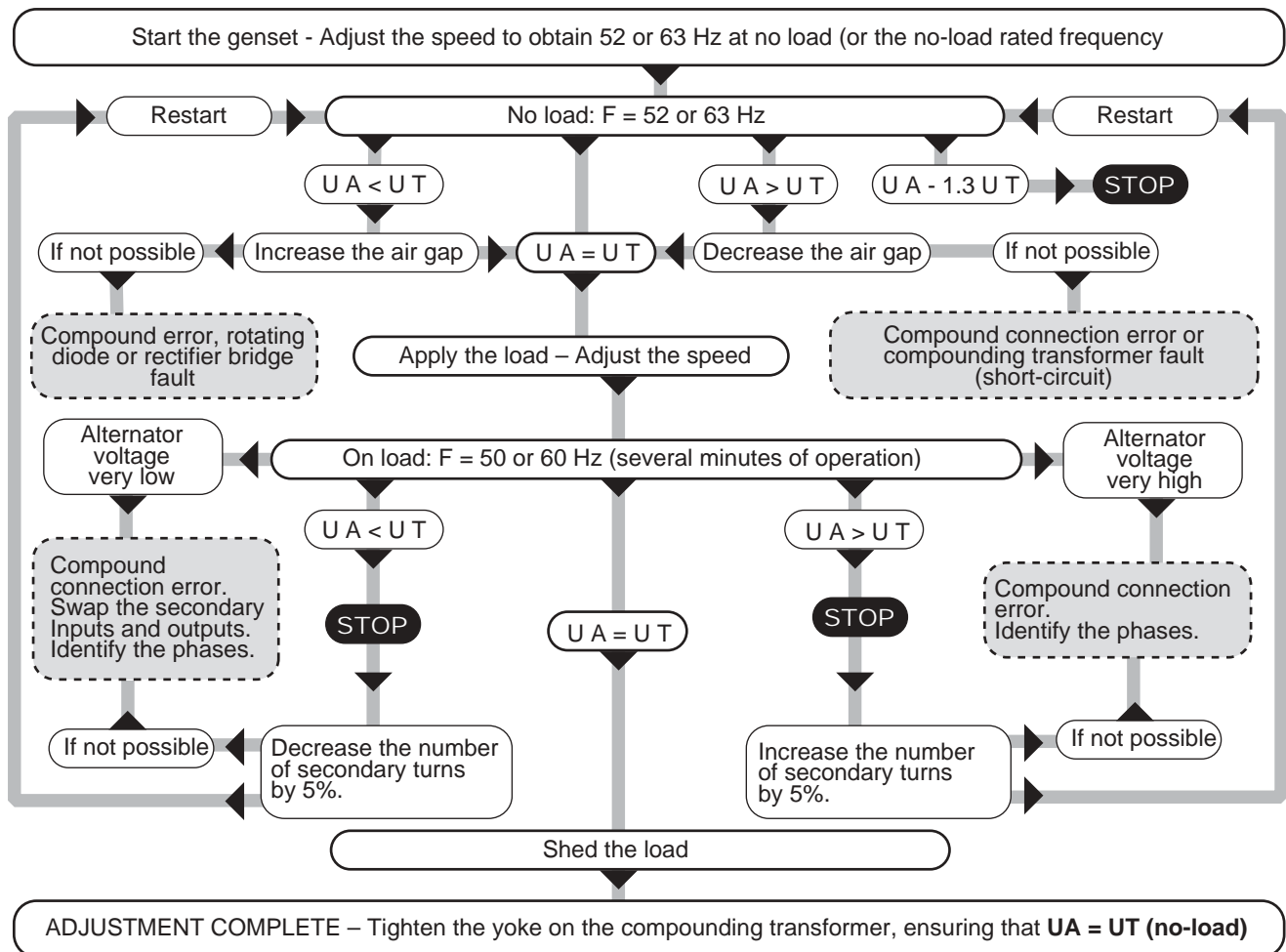

# LSA 43.2/44.2 - ACT/R - 4P ALTERNATORS INSTALLATION

## 3.10 - Identification of auxiliary winding phases in relation to stator phases

The tests to identify the auxiliary winding phases in relation to the stator phases are carried out with the alternator in no-load operation and the stator star-connected.

- Make an artificial neutral by connecting 3 resistors (220 Ω - 10W) in star configuration to the auxiliary winding terminals.

- Connect the alternator neutral to the artificial neutral on the auxiliary winding, as shown on the diagram below.

- Measure and record the following voltages:

UPHN between phase and neutral on the stator winding  
uphn between phase and neutral on the auxiliary winding  
U1, U2, U3, V1, V2, V3, W1, W2 and W3 between the main winding outputs UVW and the auxiliary winding outputs marked 1,2,3 for testing purposes.

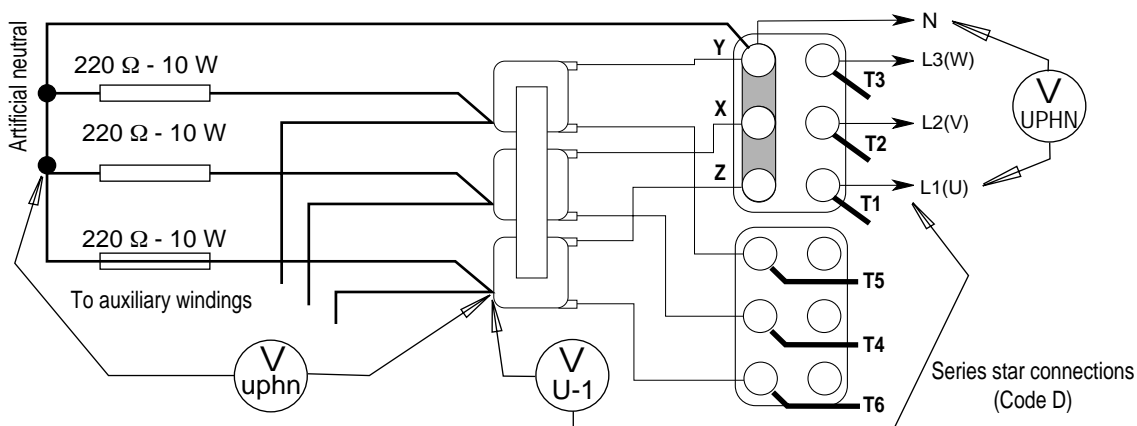

Assuming that UPHN = 220 V and uphn = 22 V  
The resulting measurements can be presented in two different forms of table, A or B.

- Table A contains 3 voltage values equal to 220 - 22 = 198 Volts and 6 values equal to 220 + (22 x 0.45) = 230 Volts

TABLE A			
Identification of aux. winding			
Main winding phase	1	2	3
U	198	230	230
V	230	230	198
W	230	198	230
1 = U - 2 = W - 3 = W			

- Table B contains 3 voltage values equal to 220 + 22 = 242 Volts and 6 values equal to 220 - (22 x 0.45) = 210 Volts

TABLE B			
Identification of aux. winding			
Main winding phase	1	2	3
U	210	242	210
V	242	210	210
W	210	210	242
1 = V - 2 = U - 3 = W			

In both cases, the 3 voltages which are less than or greater than the other 6 can be used to identify the auxiliary winding phases: phase u on the auxiliary winding is the phase with the lowest voltage in relation to the main winding phase U in example A and the phase with the highest voltage in relation to phase U in example B.

In example A, the auxiliary winding is in phase with the main winding: reconnect the auxiliary winding with that indicated by the identifier.

In example B, the auxiliary winding is in anti-phase with the main winding: reconnect the auxiliary winding by swapping

the inputs and outputs on the compounding transformer secondaries.

Note:

The 3 primary windings on the compounding transformer must be connected in the same winding direction, otherwise the compound system will not operate correctly. If, after identifying and reconnecting the windings as described above, the alternator voltage "collapses" under a low inductive load, swap the inputs and outputs on the compounding transformer secondaries.

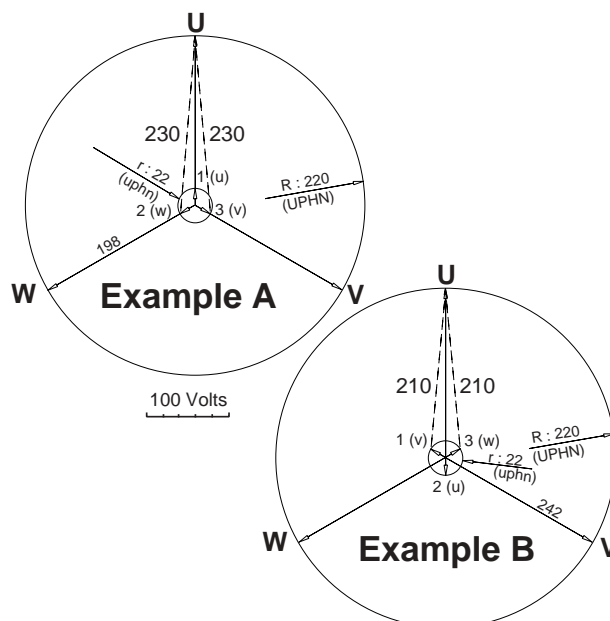

# LSA 43.2/44.2 - ACT/R - 4P

## ALTERNATORS

### SERVICING - MAINTENANCE

## 4 - SERVICING - MAINTENANCE

### 4.1 - Safety measures



**Servicing or troubleshooting must be carried out strictly in accordance with instructions so as to avoid the risk of accidents and to maintain the machine in its original state.**



**All such operations performed on the alternator should be undertaken by personnel trained in the commissioning, servicing and maintenance of electrical and mechanical components.**

Before any intervention on the machine, ensure that it cannot be started by a manual or automatic system and that you have understood the operating principles of the system.

### 4.2 - Routine maintenance

#### 4.2.1 - Checks after start-up

After approximately 20 hours of operation, check that all fixing screws on the machine are still tight, plus the general state of the machine and the various electrical connections in the installation.

#### 4.2.2 - Cooling circuit

It is advisable to check that circulation of air is not reduced by partial blocking of the air intake and outlet grilles: mud, fibre, grease, etc.

#### 4.2.3 - Bearings

The bearings are permanently greased: approximate life of the grease (depending on use) = 20,000 hours or 3 years. Monitor the temperature rise in the bearings, which should not exceed 90°C. Should this value be exceeded, the machine must be stopped and checks carried out.

#### 4.2.4 - Electrical servicing

##### Cleaning product for the windings

**CAUTION**

**Do not use: trichlorethylene, perchlorethylene, trichloroethane or any alkaline products.**

Certain strictly defined pure volatile degreasing agents can be used, such as:

- Normal petrol (without additives); inflammable
- Toluene (slightly toxic); inflammable
- Benzene (or benzene, toxic); inflammable
- Cyclohexane (non toxic); inflammable

##### Cleaning of the stator, rotor, exciter and diode bridge

The insulating components and the impregnation system are not at risk of damage from solvents (see the above list of authorised products).

Avoid letting the cleaning product run into the slots. Apply the product with a brush, sponging frequently to avoid accumulation in the housing. Dry the winding with a dry cloth. Let any traces evaporate before reassembling the machine.

#### 4.2.5 - Mechanical servicing

**CAUTION**

**Cleaning the machine using water or a high-pressure washer is strictly prohibited.**

**Any problems arising from such treatment are not covered by our warranty.**

The machine should be cleaned with a degreasing agent, applied using a brush. Check that the degreasing agent will not affect the paint.

Compressed air should be used to remove any dust.

If filters have been added to the machine after manufacture and do not have thermal protection, the service personnel should clean the air filters periodically and systematically, as often as necessary (every day in very dusty atmospheres).

These can be washed in water if it is dry dust or in a bath containing soap or detergent if it is greasy dust. Petrol or chloroethylene can also be used.

After cleaning the alternator, it is essential to check the winding insulation (see sections 3.2 and 4.8).

### 4.3 - Fault detection

If, when commissioned, the alternator does not work normally, the source of the malfunction must be identified.

To do this, check that:

- The protection devices are fitted correctly.
- The connections comply with the diagrams in the manuals supplied with the machine.
- The genset speed is correct (see section 1.3).

Repeat the operations defined in section 3.



# LSA 43.2/44.2 - ACT/R - 4P

## ALTERNATORS

### SERVICING - MAINTENANCE

#### 4.4 - Mechanical defects

Trip		Action
Bearing	Excessive overheating of one or both bearings (temperature > 80°C on the bearing retainers with or without abnormal noise)	<ul style="list-style-type: none"> <li>- If the bearing has turned blue or if the grease has turned black, change the bearing.</li> <li>- Bearing not properly seated.</li> <li>- End shields misaligned (flanges not properly fitted)</li> </ul>
Abnormal temperature	Excessive temperature rise of alternator frame (more than 40°C above the ambient temperature)	<ul style="list-style-type: none"> <li>- Air flow (intake-outlet) partially clogged or hot air is being recycled from the alternator or engine</li> <li>- Alternator operating at too high voltage (&gt; 105% of Un on load)</li> <li>- Alternator overloaded</li> </ul>
Vibration	Excessive vibration	<ul style="list-style-type: none"> <li>- Misalignment (coupling)</li> <li>- Defective mounting or play in coupling</li> <li>- Rotor balancing fault</li> </ul>
	Excessive vibration and humming noise coming from the machine	<ul style="list-style-type: none"> <li>- Alternator operating in single-phase mode (single-phase load or faulty contactor or installation fault)</li> <li>- Stator short-circuit</li> </ul>
Abnormal noise	Alternator damaged by a significant impact, followed by humming and vibration	<ul style="list-style-type: none"> <li>- System short-circuit</li> <li>- Mis-paralleling</li> </ul> <p>Possible consequences</p> <ul style="list-style-type: none"> <li>- Broken or damaged coupling</li> <li>- Broken or bent shaft end</li> <li>- Shifting and short-circuit of revolving field winding</li> <li>- Fan fractured or coming loose on shaft</li> <li>- Irreparable damage to rotating diodes or AVR</li> </ul>

#### 4.5 - Electrical faults

Trip	Action	Effect	Check/Cause
No voltage at no load on start-up	Connect a new battery of 4 to 12 V to terminals E- and E+, respecting the polarity, for 2 to 3 seconds	The alternator builds up and its voltage is still correct when the battery is removed.	<ul style="list-style-type: none"> <li>- No remanent (E- and E+ voltage approx. 10 V)</li> <li>- U &gt; 15V diode or exciter fault</li> </ul>
		The alternator builds up but its voltage does not reach the rated value when the battery is removed.	<ul style="list-style-type: none"> <li>- Check the connection of the voltage reference to the AVR</li> <li>- Re-adjust the AVR voltage potentiometer (P2)</li> </ul>
		The alternator builds up but its voltage disappears when the battery is removed	<ul style="list-style-type: none"> <li>- Faulty AVR</li> <li>- Field windings disconnected</li> <li>- Main field winding open circuit. Check the resistance</li> </ul>
Voltage too low	Check the drive speed	Correct speed	<ul style="list-style-type: none"> <li>- Check the AVR connections (possible AVR failure)</li> <li>- Field windings short-circuited</li> <li>- Rotating diodes burnt out</li> <li>- Main field winding short-circuited - Check the resistance</li> </ul>
		Speed too low	Increase the drive speed (Do not touch the AVR voltage pot. (P2) before running at the correct speed.)
Voltage too high	Adjust AVR voltage potentiometer	Adjustment ineffective	Faulty AVR
Voltage oscillations	Adjust AVR stability potentiometer	If no effect: try normal/fast recovery modes (ST2)	<ul style="list-style-type: none"> <li>- Check the speed: possibility of cyclic irregularity</li> <li>- Loose connections</li> <li>- Faulty AVR</li> <li>- Speed too low when on load</li> </ul>
Voltage correct at no load and too low when on load (*)	Run at no load and check the voltage between E+ and E- on the AVR	Voltage between E+ and E- < 15V	- Check the speed
		Voltage between E+ and E- > 20V	<ul style="list-style-type: none"> <li>- Faulty rotating diodes</li> <li>- Short-circuit in the revolving field coil. Check the resistance</li> <li>- Faulty exciter armature</li> </ul>
<b>(*) Caution:</b> For single-phase operation, check that the sensing wires coming from the AVR are correctly connected to the operating terminals.			
Voltage disappears during operation (**)	Check the AVR, the surge suppressor, the rotating diodes, and replace any defective components	The voltage does not return to the rated value	<ul style="list-style-type: none"> <li>- Exciter winding open circuit</li> <li>- Faulty exciter armature</li> <li>- Faulty AVR</li> <li>- Revolving field coil open circuit or short-circuited</li> </ul>
<b>(**) Caution:</b> Internal protection may be activated (overload, open circuit, short-circuit).			

# LSA 43.2/44.2 - ACT/R - 4P

## ALTERNATORS

### SERVICING - MAINTENANCE

#### 4.5.1 - Checking the winding

You can check the winding insulation by performing a high voltage test. In this case, you must disconnect all AVR wires.

**CAUTION**

Damage caused to the AVR in such conditions is not covered by our warranty.

#### 4.5.2 - Checking the diode bridge



A diode in good working order will only allow the current to flow from the anode to the cathode.

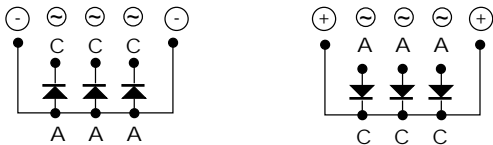
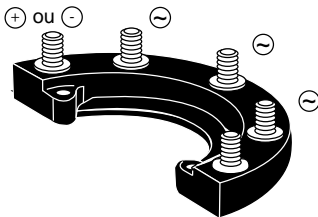

#### 4.5.3 - Checking the windings and rotating diodes using separate excitation



During this procedure, make sure that the alternator is disconnected from any external load and inspect the terminal box to check that the connections are fully tightened.

- 1) Stop the genset, disconnect and isolate the AVR wires.
- 2) There are two ways of creating an assembly with separate excitation.

**Assembly A:** Connect a 12 V battery in series with a rheostat of approximately 50 ohms - 300 W and a diode on both exciter field wires (5+) and (6-).

ASSEMBLY A

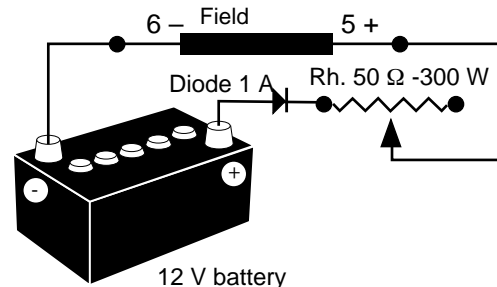

**Assembly B:** Connect a "Variac" variable power supply and a diode bridge on both exciter field wires (5+) and (6-).

Both these systems should have characteristics which are compatible with the field excitation power of the machine (see the nameplate).

3) Run the genset at its rated speed.

4) Gradually increase the exciter field supply current by adjusting the rheostat or the Variac and measure the output voltages on L1 - L2 - L3, checking the excitation voltage at no load and on load (see machine nameplate or ask for the factory test report).

When the output voltage is at its rated value and balanced within 1% for the rated excitation level, the machine is in good working order. The fault therefore comes from the AVR or its associated wiring (i.e. sensing, auxiliary windings).

ASSEMBLY B

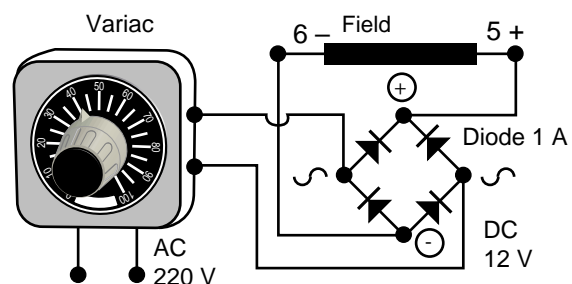

# LSA 43.2/44.2 - ACT/R - 4P

## ALTERNATORS

### SERVICING - MAINTENANCE

#### 4.5.4 - Checking the fixed diode bridge RC 06 (163)

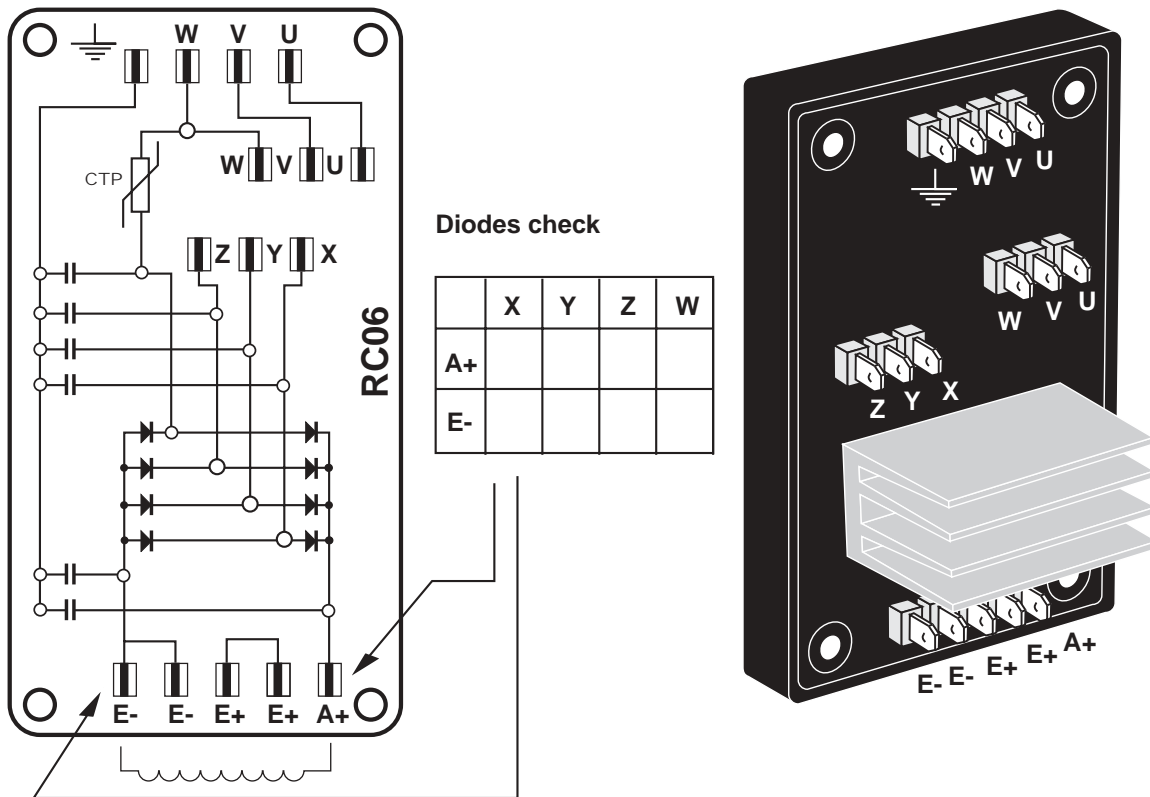

Build-up by separate excitation (no load)  
 The alternator builds up due only to the residual magnetism in the exciter's magnetic circuit. For initial commissioning (in the factory) or following an incident, this magnetic circuit must be re-magnetised.  
 To do this, connect a battery (4-12 V) to the exciter field terminals for 2 to 3 seconds. This operation should be performed with the alternator running at its rated speed.

#### 4.6 - Dismantling, reassembly

(see sections 5.4.1 & 5.4.2)



During the warranty period, this operation should only be carried out in an LEROY-SOMER approved workshop or in our factory, otherwise the warranty may be invalidated.

**CAUTION**

Whilst being handled, the machine should remain horizontal (rotor not locked when moved).

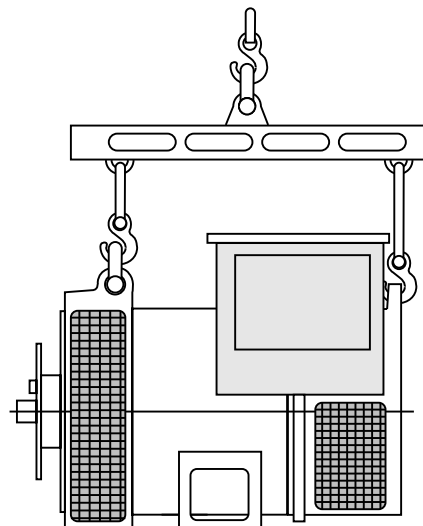

# LSA 43.2/44.2 - ACT/R - 4P

## ALTERNATORS

### SERVICING - MAINTENANCE

#### 4.6.1 - Tools required

To fully dismantle the machine, we recommend using the tools listed below:

- 1 ratchet spanner + extension
- 1 torque wrench
- 1 set of flat spanners
- 1 x 8 mm socket
- 1 x 10 mm socket
- 1 x 13 mm socket
- 1 size 5 Allen key (e.g. Facom: ET5)
- 1 size 6 Allen key (e.g. Facom: ET6)
- 1 TORX T20 bit
- 1 TORX T30 bit
- 1 puller (e.g. Facom: U35)
- 1 puller (e.g. Facom: U32/350).

#### 4.6.2 - Screw tightening torque

IDENTIFICATION	Screw Ø	Torque N.m
Field terminal block screw	M4	4 N.m
Field screw	M6	10 N.m
Diode bridge screw	M6	5 N.m
Diode nut	M5	4 N.m
Tie rod	M8	20 N.m
Earth screw	M6	5 N.m
Balancing bolt	M5	4 N.m
Disc/shaft screw	M10	66 N.m
Lifting screw	M8	4 N.m
Grille screws	M6	5 N.m
Cover screws	M6	5 N.m

#### 4.6.3 - Access to connections and the regulation system

The terminals are accessed directly by removing the terminal box lid [48].

To access the AVR adjustment potentiometers, the side plate [367] should be removed.

#### 4.6.4 - Accessing, checking and replacing diodes

##### 4.6.4.1 - Dismantling

- Remove the terminal box lid [48].
- Remove the air intake grille [51].
- Unscrew the fixing clamps on the power output cables, disconnect E+, E- from the exciter and the R 791 module.
- Remove the 4 nuts on the tie rods.
- Remove the NDE shield [36] using a puller: exemple U.32 - 350 (Facom).
- Remove the surge suppressor [347].
- Remove the 4 fixing screws from the diode bridges on the armature and disconnect the diodes.
- Check the 6 diodes using an ohmmeter or a battery lamp (see section 4.5.2).

##### 4.6.4.2 - Reassembly

- Replace the bridges, respecting the polarity (see section 4.5.2).
- Replace the surge suppressor [347].
- Fit a new O ring seal in the shield.

- Refit the NDE shield and pass the bundle of wires between the top bars of the shield.
- Refit the fixing clamps on the cables and the R 791 module.
- Refit the air intake grille [51].
- Replace the terminal box lid [48].

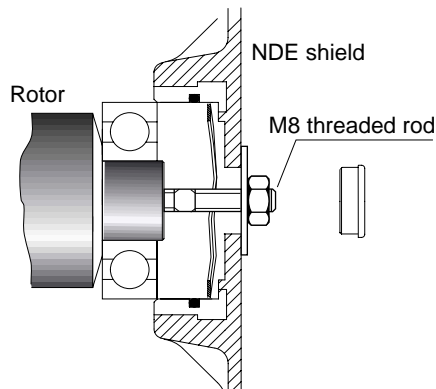

#### 4.6.5 - Replacing the NDE bearing on single-bearing machines

##### 4.6.5.1 - Dismantling

- Remove the NDE shield [36] (see section 4.6.2.1).
- Remove the ball bearing [70] using a screw puller.

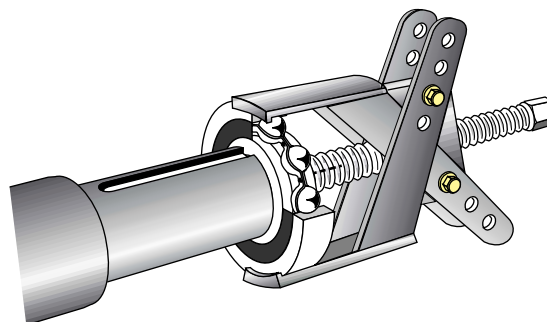

##### 4.6.5.2 - Reassembly

- Heat the inner slip-ring of a new bearing by induction or in a drying oven at 80 °C (do not use an oil-bath) and fit it to the machine.
- Place the preloading wavy washer [79] in the shield and fit a new O ring seal [349].
- Replace the NDE shield [36] (see section 4.6.2.2).

#### 4.6.6 - Replacing the bearings on two-bearing machines

##### 4.6.6.1 - Dismantling

- Uncouple the alternator from the prime mover.
- Remove the 8 assembly screws.
- Remove the DE shield [30].
- Remove the NDE shield (see section 4.6.2.1).
- Remove both ball bearings [60] and [70] using a puller with a central screw.

##### 4.6.6.2 - Reassembly

- Heat the new bearings by induction or in a drying oven at 80°C (do not use an oil-bath) and fit them to the machine.
- Check that both the preloading wavy washer [79] and the new O ring seal [349] have been fitted on the NDE shield [36].
- Replace the DE shield [30] and tighten the 8 fixing screws.
- Check that the machine assembly is correctly mounted and that all screws are tightened.

# LSA 43.2/44.2 - ACT/R - 4P

## ALTERNATORS

### SERVICING - MAINTENANCE

#### 4.6.7 - Accessing the main field and stator

##### 4.6.7.1 - Dismantling

Follow the procedure for dismantling the bearings (see sections 4.6.5.1 and 4.6.5.1).

- Remove the coupling disc (single-bearing machine) or the DE shield (two-bearing machine) and insert a tube of the corresponding diameter on the shaft end or a support made according to the following diagram.

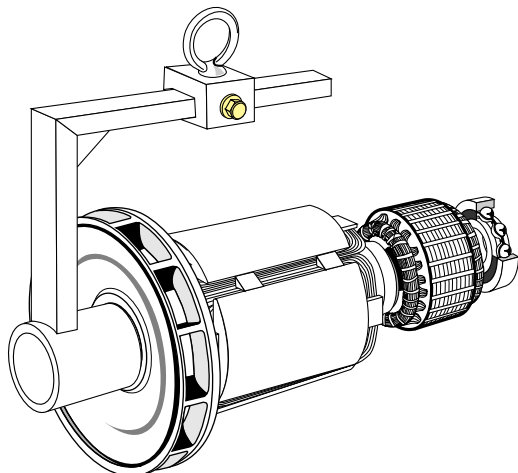

- Rest the rotor on one of its poles, then slide it out. Use the tube as a lever arm to assist dismantling.  
 - After extracting the rotor, be careful not to damage the fan. If the fan is dismantled, it is essential that it is replaced.

**NOTE:** If intervention is required on the main field (rewinding, replacement of components), the rotor assembly must be rebalanced.

##### 4.6.7.2 - Reassembling the main field

- Follow the dismantling procedure in reverse order. Take care not to knock the windings when refitting the rotor in the stator.  
 - If the fan is being replaced, assemble the parts as shown in the following diagram. Fit a tube and a threaded screw.

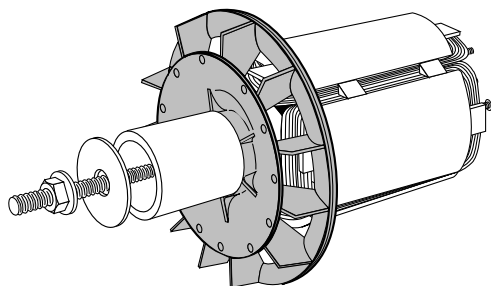

Follow the procedure for dismantling the bearings (see sections 4.6.5.2 and 4.6.6.2).



After operational testing, replace all access panels or covers.

#### 4.7 - Electrical characteristics

Table of average values:

Alternator - 2 and 4-pole - 50 Hz/60 Hz - Winding no. 51 (400 V for the excitation values).

The voltage and current values are given for no-load operation and operation at rated load with separate field excitation. All values are given at ± 10% (for exact values, consult the test report) and are subject to change without prior warning. For 60 Hz operation, the resistance values are the same and the excitation current "i exc" is approximately 5 to 10% weaker.

##### LSA 43.2: Resistances at 20°C (Ω)

LSA 43.2	S1	S2	S3	M4	L6	L7
L/N stator	0.1265	0.1265	.	.	0.0766	0.0534
Rotor	1.346	1.346	.	.	1.757	1.953
Exciter field	9.2	9.2	.	.	9.2	9.2
Armature	0.23	0.23	.	.	0.23	0.23

##### LSA 43.2: Excitation current i exc (A) - 400 V - 50 Hz

"i exc": excitation current of the exciter field

LSA 43.2	S1	S2	S3	M4	L6	L7
No load	1.35	1.35	.	.	1.07	1.17
On load	2.77	2.77	.	.	2.91	2.7
kVA	30	30	.	.	60	60

##### LSA 44.2: Resistances at 20°C (Ω)

LSA 44.2	VS3	VS4	S7	M9	L11	L12
L/N stator	0.0389	0.0389	0.0284	0.0284	0.016	0.016
Rotor	2.57	2.57	2.96	2.96	3.74	3.74
Exciter field	4.92	4.92	4.92	4.92	4.92	4.92
Armature	0.29	0.29	0.29	0.29	0.29	0.29

##### LSA 44.2: Excitation current i exc (A) - 400 V - 50 Hz

"i exc": excitation current of the exciter field

LSA 44.2	VS3	VS4	S7	M9	L11	L12
No load	1.36	1.36	1.31	1.31	1.52	1.52
On load	4	4.17	3.47	3.47	3	3
kVA	90	100	100	100	100	100

# LSA 43.2/44.2 - ACT/R - 4P

## ALTERNATORS

### SPARE PARTS

## 5 - SPARE PARTS

### 5.1 - First maintenance parts

Emergency repair kits are available as an option.

They contain the following items:

Ref.	Description	Qty	LSA 43.2/44.2	Code
198	AVR	1	R 129	
343	Diode bridge assembly	1	LSA 432.9.03/04	ESC 040 MD 003
347	Surge suppressor	1	LSA 432.1.13	CII 111 PM 002
163	Fixed rectifier bridge	1	RC 06	

### 5.2 - Bearing designations

Ref.	Description	Qty	LSA 43.2	Code	LSA 44.2	Code
60	DE bearing	1	6312 2RS/C3	RLT 060 TS 030	6315 2RS/C3	RLT 075 TS 030
70	NDE bearing	1	6307 2RS/C3	RLT 080 RB 002	6309 2RS/C3	RLT 100 RB 005

### 5.3 - Technical support service

Our technical support service will be pleased to provide any additional information you may require.

**CAUTION**

**When ordering spare parts, you should indicate the complete machine type, its serial number and the information given on the nameplate.**

Address your enquiry to your usual contact, or to:

#### MOTEURS LEROY-SOMER

Usine de Sillac/Alternateurs

16015 ANGOULEME CEDEX - FRANCE

Tel.: (33) 05.45.64.45.64

Technical Support Service:

(33) 05.45.64.43.66 - (33) 05.45.64.43.67 -

(33) 05.45.64.43.68 - (33) 05.45.64.43.69

Fax: (33) 05.45.64.43.24

email: sat.sil@leroysoyer.com

**Part numbers should be identified from the exploded views and their description from the parts list.**

**Our extensive network of service centres can dispatch the necessary parts without delay.**

**To ensure correct operation and the safety of our machines, we recommend the use of original manufacturer spare parts.**

**In the event of failure to comply with this advice, the manufacturer cannot be held responsible for any damage.**

# LSA 43.2/44.2 - ACT/R - 4P ALTERNATORS SPARE PARTS

## 5.4 - Exploded view, parts list

### 5.4.1 - LSA 43.2/44.2 single-bearing

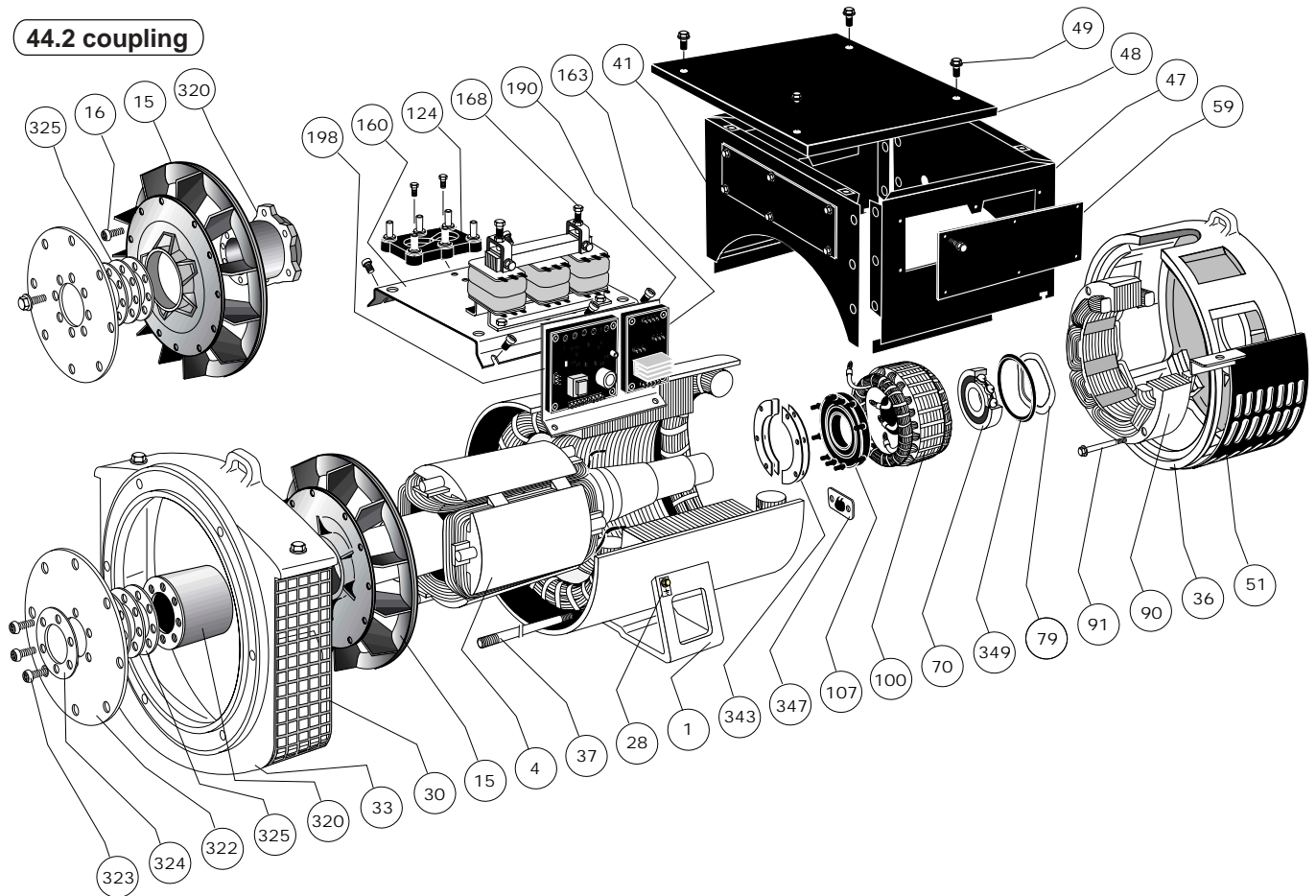

No.	Nbr	Description	No.	Nbr	Description
1	1	Stator assembly	91	4	Exciter field fixing screw
4	1	Rotor assembly	100	1	Exciter armature
15	1	Fan	107	1	Diode crescent support
16	6	Fixing screws (44.2)	124	1	Terminal block
28	1	Earth terminal	160	1	Compounding plate
30	1	DE shield	163	1	Fixed rectifier bridge
33	1	Air outlet grille	168	1	Compounding transformer
36	1	NDE shield	190	1	AVR support
37	4	Tie rod	198	1	Voltage regulator (AVR)
41	1	Cowling	320	1	Sleeve
47	1	Cowling	322	1	Coupling disc
48	1	Cover top panel	323	6	Fixing screws
49	20	Fixing screws	324	1	Clamping washer
51	1	Air intake grille	325	-	Spacer washer
59	1	Inspection door	343	1	Direct diode cap
70	1	Non drive end bearing	347	1	Surge suppressor
79	1	Preloading (wavy) washer	349	1	'O' ring seal
90	1	Exciter field			

# LSA 43.2/44.2 - ACT/R - 4P ALTERNATORS SPARE PARTS

## 5.4.2 - LSA 43.2/44.2 two-bearing

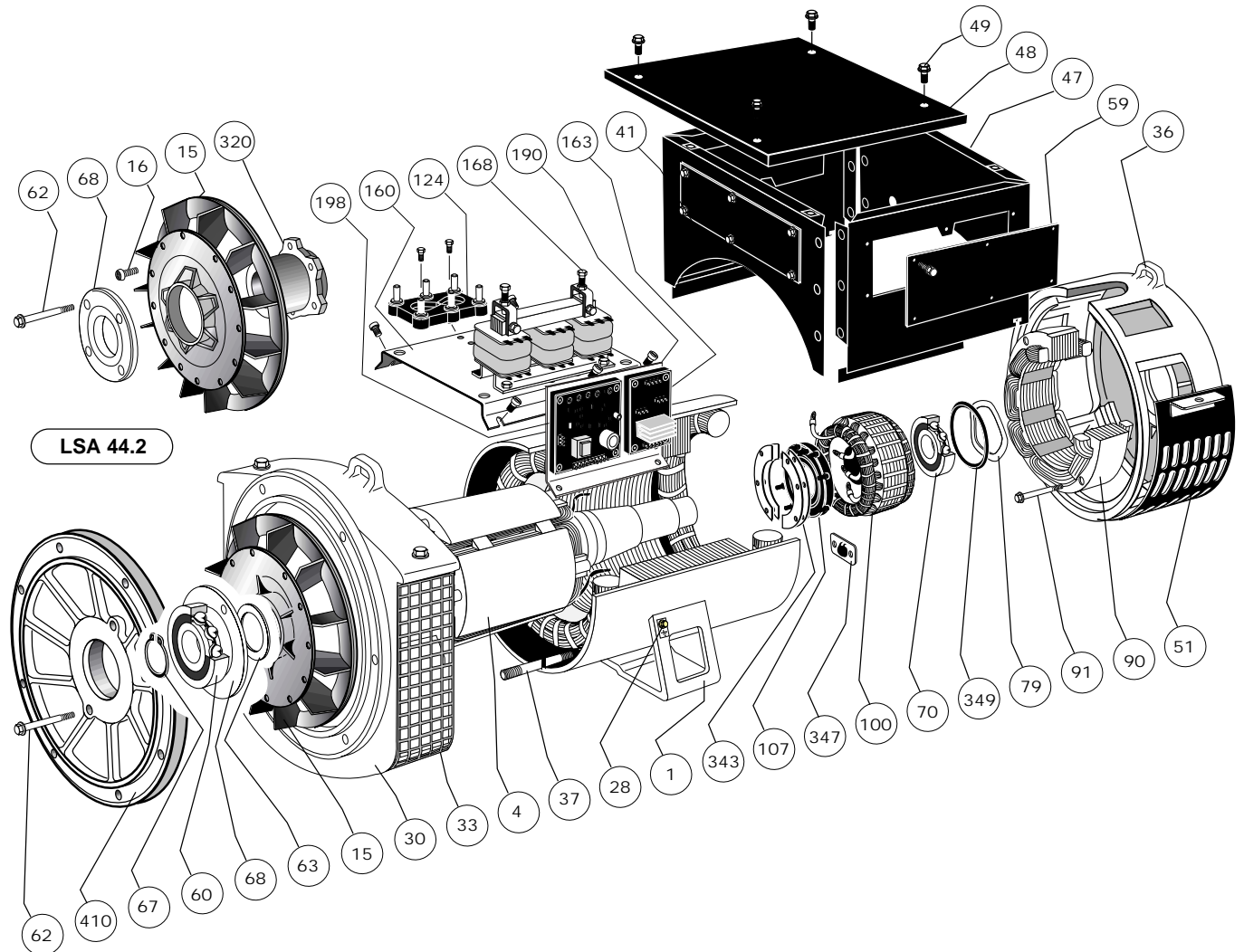

No.	Nbr	Description	No.	Nbr	Description
1	1	Stator assembly	67	1	Circlip
4	1	Rotor assembly	68	1	Thrust bearing
15	1	Fan	70	1	Non drive end bearing
16	6	Fan fixing screw	79	1	Preloading (wavy) washer
28	1	Earth terminal	90	1	Exciter field
30	1	DE shield	91	4	Exciter field fixing screw
33	1	Air outlet grille	100	1	Exciter armature
36	1	NDE shield	107	1	Diode crescent support
37	4	Tie rod	124	1	Terminal block
41	1	Cowling	160	1	Compounding plate
47	1	Cowling	163	1	Fixed rectifier bridge
48	1	Cover top panel	168	1	Compounding transformer
49	20	Fixing screws	190	1	AVR support
51	1	Air intake grille	198	1	Voltage regulator (AVR)
59	1	Inspection door	343	1	Direct diode cap
60	1	Drive end bearing	347	1	Surge suppressor
62	2	Fixing screws	349	1	'O' ring seal
63	1	Washer	410	1	End shield



**LSA 43.2/44.2 - ACT/R - 4P**  
**ALTERNATORS**  
NOTES

**LSA 43.2/44.2 - ACT/R - 4P**  
**ALTERNATORS**  
NOTES



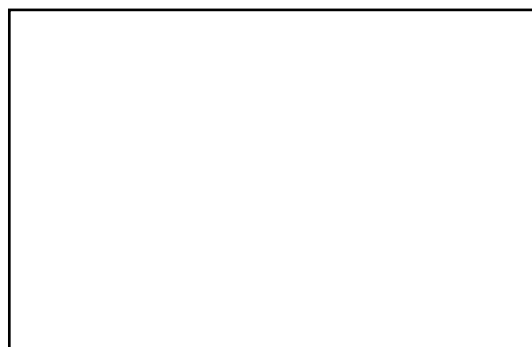

MOTEURS LEROY-SOMER 16015 ANGOULÊME CEDEX - FRANCE

338 567 258 RCS ANGOULÊME  
S.A. au capital de 62 779 000 €

[www.leroy-somer.com](http://www.leroy-somer.com)